



# Fraunhofer

LIGHT & SURFACES

[WWW.LIGHT-AND-SURFACES.FRAUNHOFER.DE](http://WWW.LIGHT-AND-SURFACES.FRAUNHOFER.DE)

## FRAUNHOFER GROUP FOR LIGHT & SURFACES PHOTONIC PRODUCTION

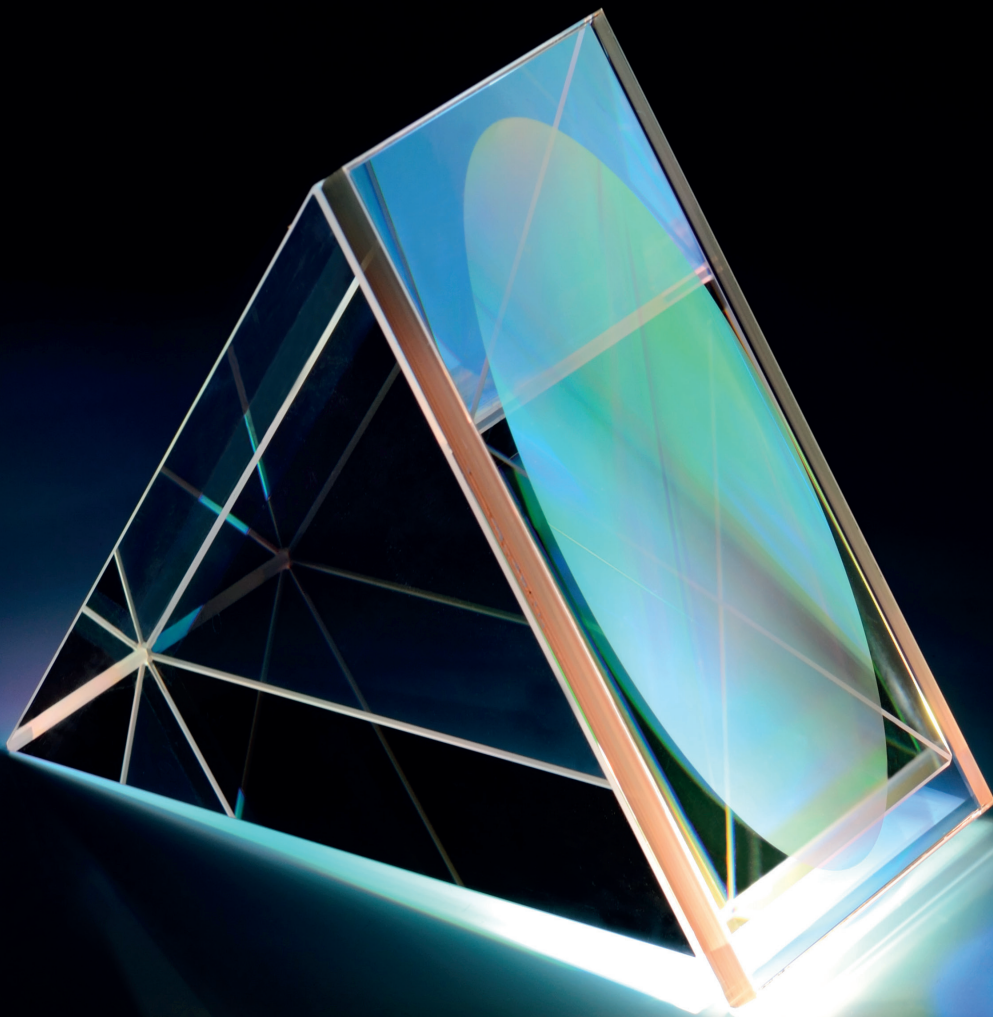



## CONTENTS

<b>Light – Laser technology drives numerous innovations</b>	<b>3</b>
<b>The group institutes</b>	<b>4</b>
<b>Core competencies</b>	
• Laser manufacturing	6
• Beam sources	8
• Metrology	10
• Medicine and life sciences	12
• Optical systems and optics manufacturing	14
• EUV technology	16
• Process and system simulation	18

## LIGHT – LASER TECHNOLOGY DRIVES NUMEROUS INNOVATIONS

Within the Fraunhofer Group for Light & Surfaces, six Fraunhofer institutes cooperate in the fields of lasers, optics, metrology and coating technology. The institutes combine complementary skills in the following areas: laser manufacturing techniques, beam sources, metrology, medicine and life sciences, optical systems and optics manufacturing, EUV technology, process and system simulation, materials technology, micro- and nanotechnologies, and thin-film, plasma and electron beam technology.

### Competency by networking

Building on their basic research in the various fields of application, the institutes work together to supply fast, flexible and customer-specific system solutions in the fields of coating technology and photonics. Strategy is coordinated to reflect current market requirements, yielding synergies that benefit the customer. The institutes also collaborate with their local universities to provide the full range of student education, up to and including doctoral studies. As a result, the Fraunhofer institutes are not only partners to technological development, but also a continuous source of new talent in the fields of coating technology and photonics.

### Core competencies of the group

The Fraunhofer institutes' competencies are coordinated to ensure that research can be quickly and flexibly adapted to the requirements of the various fields of application:

- Laser manufacturing
- Beam sources
- Metrology
- Medicine and life sciences
- Materials technology
- Optical systems and optics manufacturing
- Micro- and nanotechnologies
- Thin-film technology

- Plasma technology
- Electron beam technology
- EUV technology
- Process and system simulation

### Fields of application

The Fraunhofer institutes are able to draw on extensive process expertise to provide customers with tailored, laser- and process-specific solutions that take material and product design, construction, means of production and quality assurance into account. These solutions serve a wide range of industries:

- Automotive
- Biotechnology and life sciences
- Electronics and sensor technology
- Energy and the environment
- Aerospace
- Mechanical and plant engineering, tool and die manufacturing
- Optics

*1 Glass being structured using direct laser ablation with an ultrashort pulsed laser beam.*

# THE INSTITUTES

## **Fraunhofer Institute for Organic Electronics, Electron Beam and Plasma Technology FEP**

The Fraunhofer FEP works on innovative solutions in the fields of vacuum coating, surface treatment as well as organic semiconductors. The core competencies electron beam technology, sputtering, plasma-activated deposition and high-rate PECVD as well as technologies for organic electronics and IC/system design provide a basis for these activities. Fraunhofer FEP continuously enhances them and makes them available to a wide range of industries: mechanical engineering, transport, biomedical engineering, architecture and preservation, packaging, environment and energy, optics, sensor technology and electronics as well as agriculture.

[www.fep.fraunhofer.de/en](http://www.fep.fraunhofer.de/en)

## **Fraunhofer Institute for Laser Technology ILT**

With more than 400 employees the Fraunhofer ILT develops innovative laser beam sources, laser technologies, and laser systems for its partners from the industry. Our technology areas cover the following topics: laser and optics, medical technology and biophotonics, laser measurement technology and laser material processing. This includes laser cutting, caving, drilling, welding and soldering as well as surface treatment, micro processing and additive manufacturing. Furthermore, the Fraunhofer ILT is engaged in laser plant technology, process control, modeling as well as in the entire system technology.

[www.ilt.fraunhofer.de/en](http://www.ilt.fraunhofer.de/en)

## **Fraunhofer Institute for Applied Optics and Precision Engineering IOF**

The Fraunhofer IOF develops innovative optical systems to control light from the generation to the application. Our service range covers the entire photonic process chain from opto-mechanical and opto-electrical system design to the manufacturing of customized solutions and prototypes. The institute works in the five business fields of Optical Components and Systems, Precision Engineering Components and Systems, Functional Surfaces and Layers, Photonic Sensors and Measuring Systems and Laser Technology.

[www.iof.fraunhofer.de/en](http://www.iof.fraunhofer.de/en)

## **Fraunhofer Institute for Physical Measurement Techniques IPM**

The Fraunhofer IPM develops tailor-made measuring techniques, systems and materials for industry. In this way we enable our customers to minimize their use of energy and resources while at the same time maximizing quality and reliability. Fraunhofer IPM makes processes more ecological and at the same time more economical. Many years of experience with optical technologies and functional materials form the basis for high-tech solutions in the fields of production control, materials characterization and testing, object and shape detection, gas and process technology as well as functional materials and systems.

[www.ipm.fraunhofer.de/en](http://www.ipm.fraunhofer.de/en)

## **Fraunhofer Institute for Surface Engineering and Thin Films IST**

As an innovative R&D partner the Fraunhofer IST offers complete solutions in surface engineering which are developed in cooperation with customers from industry and research. The IST's »product« is the surface, optimized by modification, patterning, and/or coating for applications in the business units mechanical engineering, tools and automotive technology, aerospace, energy and electronics, optics, and also life science and ecology. The extensive experience of the Fraunhofer IST with thin-film deposition and film applications is complemented by excellent capabilities in surface analysis and in simulating vacuum-based processes.

[www.ist.fraunhofer.de/en](http://www.ist.fraunhofer.de/en)

## **Fraunhofer Institute for Material and Beam Technology IWS**

The Fraunhofer IWS is known for its innovations in the business units joining and cutting as well as in the surface and coating technology. Across all business units our interdisciplinary topics include energy storage systems, energy efficiency, additive manufacturing, lightweight construction and big data. Our special feature is the expertise of our scientists in combining the profound know-how in materials engineering with the extensive experience in developing system technologies. Every year, numerous solutions with regard to laser material processing and coating technology have been developed and have found their way into industrial applications.

[www.iws.fraunhofer.de/en](http://www.iws.fraunhofer.de/en)

## **Contact – Fraunhofer Group for Light & Surfaces**

Prof. Reinhart Poprawe (Chairman)  
Steinbachstraße 15  
52074 Aachen, Germany  
[reinhart.poprawe@ilt.fraunhofer.de](mailto:reinhart.poprawe@ilt.fraunhofer.de)

Dr. Arnold Gillner (Managing Director)  
Steinbachstraße 15  
52074 Aachen, Germany  
[arnold.gillner@ilt.fraunhofer.de](mailto:arnold.gillner@ilt.fraunhofer.de)

[www.light-and-surfaces.fraunhofer.de/en](http://www.light-and-surfaces.fraunhofer.de/en)



# LASER MANUFACTURING

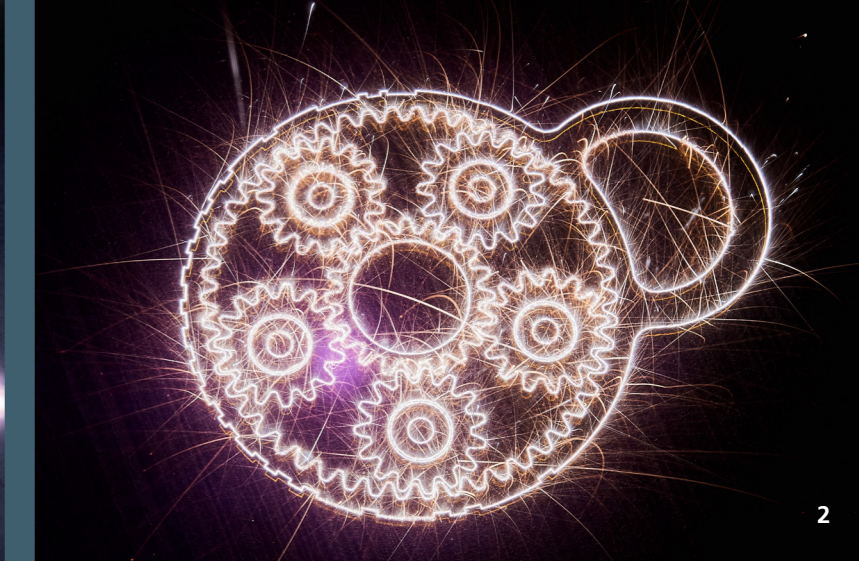
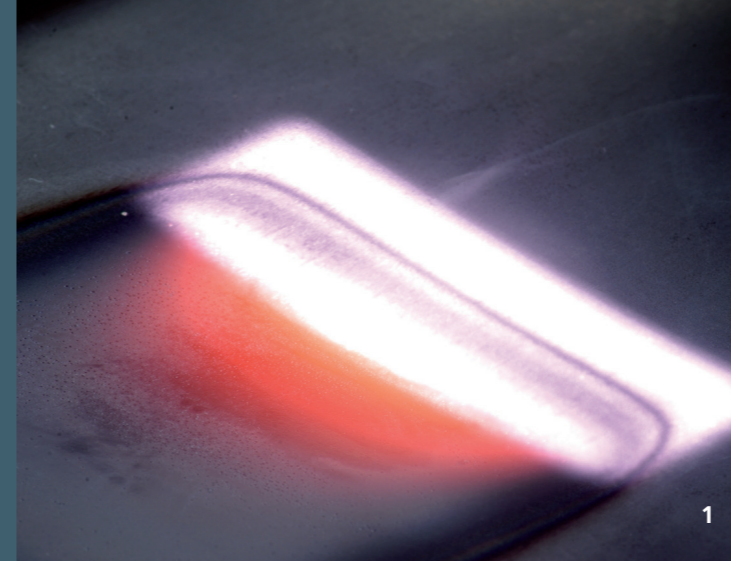

Joining processes such as laser welding, laser soldering and laser bonding are employed, for instance, in the automotive industry, in electrical engineering and electronics, and in medical technology. The services offered by the member institutes of the Fraunhofer Group for Light & Surfaces range from feasibility studies and process validation to the integration of laser technology into industrial production – taking into account the specific challenges posed by the various materials, processes and systems. In the biomedical field, laser-based techniques are used to print living cells to produce biological and biohybrid implants.

## Applications

- Laser joining
- Laser ablation
- Additive manufacturing
- Laser functionalization

## LASER JOINING

Fraunhofer ILT, Fraunhofer IOF and Fraunhofer IWS each develop customized processes, tools and systems to facilitate laser-based joining for macroscopic and microscopic applications. These processes achieve high joining speeds, optimized

connection geometry and minimized heat influence and distortion. Researchers have in-depth knowledge of the materials involved, including metals, (fiber-reinforced) plastics, glass and silicon, enabling them to use special alloy compositions in the weld seam to avoid cracks and volume defects. Laser deposition welding is a technique that can be used to produce wear-resistant coatings on any substrate, as well as to repair degraded areas of fusible components. Laser beam soldering can melt solder without contact in electronics and manufacturing applications. It also enables precise distribution of energy input to the solder and the parts to be joined, ensuring that the solder goes exactly where the user wants it. Laser beam bonding is a melt-free process that is particularly suitable for encapsulating microsystems and thermally sensitive components, allowing, for instance, for the joining of amorphous and crystalline optics that are subject to heavy loads.

## LASER ABLATION

Group institutes Fraunhofer ILT, Fraunhofer IOF and Fraunhofer IWS develop processes, technologies and systems for laser ablation. In addition to using a wide variety of materials, such as metals, ceramics, plastics and glasses, they also focus on various process technologies. High-performance ultrafast lasers with picosecond and femtosecond pulse widths are yielding ever higher-quality results in manufacturing technology. Fraunhofer ILT and Fraunhofer IWS develop and are at the forefront of such laser-cutting techniques as high-speed cutting, thick-section cutting and remote laser cutting, as well as processes for laser fusion cutting. In the field of laser drilling, the institutes can also draw on such techniques as single-pulse drilling, percussion drilling and helical drilling.

## ADDITIVE MANUFACTURING LASER FUNCTIONALIZATION

The member institutes of the Fraunhofer Group for Light & Surfaces are actively involved in the development of process technology and machine designs for additive manufacturing. Powder-bed processes such as selective laser melting (SLM) are the process of choice for producing components with the highest possible degree of geometric freedom. The range of materials that can be used with this process includes steel, nickel and cobalt alloys, titanium lightweight materials, carbide metals and ceramics. In the case of electron beam melting (EBM), an electron beam is used in place of a laser beam to process the ceramic or metallic powder bed. Laser metal deposition (LMD), in contrast, employs powdered additives. As regards thin-film printing, Fraunhofer IWS is concentrating its efforts on developing paste- and ink-based processes that allow for 3D multimaterial printing and polymer composite structures. It is also pursuing new polymer-based additive techniques such as stereolithography, multiphoton lithography and digital light processing, which are particularly suitable for printing polymer microstructures and for actuating materials. Laser sintering is also used in addition to pure melting techniques.

Laser-based functionalization makes it possible to selectively adjust specific material properties and alter intrinsic ones, with the functionalization being restricted solely to the zone of irradiation. Member institutes employ both thermal techniques (laser hardening, laser cladding) and non-thermal techniques (plasma spraying, photofunctionalization) using UV, diode, solid-state and CO<sub>2</sub> lasers. Fraunhofer IWS offers hardening techniques such as laser-beam hardening, heat treatment and soldering, and laser-assisted roll cladding. Fraunhofer ILT researches local heat-treatment techniques for the post-treatment of high-strength steels, as well as laser techniques for micro- and macrofunctionalization. Fraunhofer IST uses laser functionalization for post-processing surfaces produced, for instance, by cold plasma spraying. In this process, the coating is applied with a plasma jet infused with various solutions, dispersions or (sub-)micropowders. This special plasma generation technique enables even thermally sensitive substrates and natural materials to be coated.

- 1 Localized heat treatment of high-strength steel blanks.
- 2 A planetary gearhead manufactured using SLM.



# BEAM SOURCES

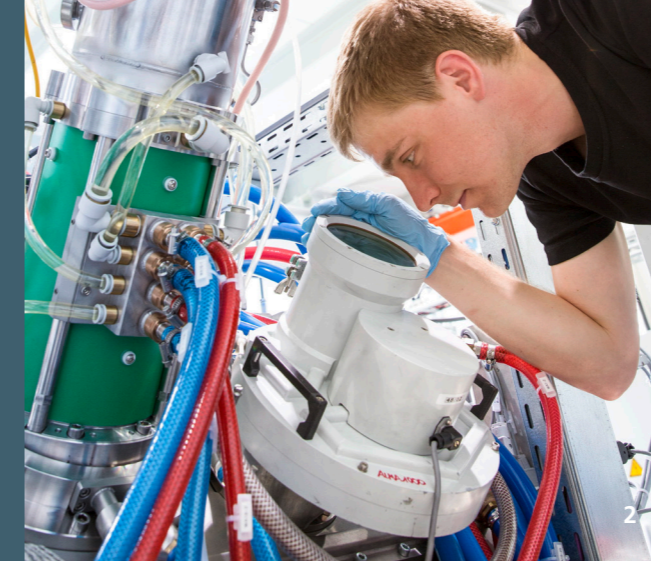
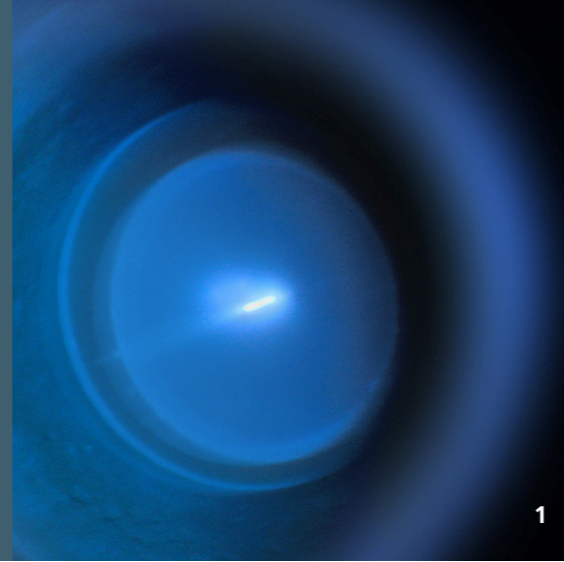

The various member institutes develop laser beam, electron beam, plasma, X-ray and EUV sources for specific customer requirements, such as aircraft- and satellite-based environmental metrology. In addition, the institutes focus on innovative laser beam sources and high-quality optical components and systems for laser material processing. The range of laser beam sources extends from diode lasers to fiber and solid-state lasers, from high-power CW lasers to ultrafast lasers, and from single-frequency systems to broadband tunable lasers.

## Applications

- Laser beam sources
- Electron beam sources
- Plasma sources
- X-ray sources

## LASER BEAM SOURCES

The laser experts at the member institutes develop optical components and systems for beam sources with customized spatial, temporal and spectral properties. Their expertise encompasses solid-state lasers, amplifiers and high-power fiber laser systems. In the case of solid-state lasers, their primary focus is on oscillators and amplifier systems with excellent performance data. Whether laser manufacturers or end users, customers receive custom-made prototypes designed specifically for their individual requirements, as well as guidance on how to optimize their existing systems. Particularly in the field of short-pulse lasers and broadband amplifiers, the institutes have numerous patents and record results to serve as a reference point. Fraunhofer ILT concentrates primarily on slab and disk laser amplifiers that can be scaled up to the multi-kW range. Fraunhofer IOF develops high-power fiber laser systems ranging from single-frequency beam sources to ultrashort pulse systems, with diffraction-limited output beams up into the kW range. The institutes also offer technological solutions for beam shaping and beam guidance, frequency conversion, packaging of high-performance optical components and design of optical components such as free-form optics.

1 Discharge-produced plasma.

2 Electron beam source.

3 Deep and contour-accurate surface

functionalization using the »Disk-Jet – DBD«

dielectric barrier surface-discharge plasma source.

## ELECTRON BEAM SOURCES

Electron beam sources are used in a number of processes involved in materials processing. Some of the best-known applications are welding, hardening, PVD coating, surface sterilization and the modification of plastics. Here, Fraunhofer FEP develops technologies and processes that can be scaled up for industrial facilities and that enable the retrofitting of existing facilities. Package solutions are tailored to individual customer requirements and may include beam control; arc protection circuitry; power, beam position and sweep generators; and electron beam sources.

## PLASMA SOURCES

Plasmas are a versatile tool when applied to coating technology, surface activation, cleaning and functional structuring. The member institutes of the Fraunhofer Group for Light & Surfaces develop both applications for plasma technology and the system components required for them. Fraunhofer IST develops and researches new and specialized plasma sources for industrial applications, particularly surface activation and coating, precision surface cleaning, application of functional groups, biomedical sterilization and plasma diffusion. The physical foundations of these sources are low-pressure glow discharges and dielectric barrier discharges at atmospheric pressure. Plasma technology is an important tool in coating technology applications, particularly as it enables the quality of the coating to be controlled while retaining high productivity.

One way to achieve faster and faster coating rates is to increase particle energy by activating the plasma during evaporation. This requires powerful sources for dense plasmas that are adapted for both high coating rate and large-area coating. Fraunhofer FEP developed these kinds of processes by combining high-rate deposition with differently guided arc discharges (SAD and HAD process).

## X-RAY SOURCES

Fraunhofer ILT develops X-ray sources for use in such applications as lithography and chip production metrology. Extreme ultraviolet and soft X-ray radiation in spectral ranges between 1 and 50 nm is generated from dense, hot plasmas, making it possible to construct compact and powerful radiation sources. Fraunhofer ILT researches and employs both laser-produced plasmas (LPP) and discharge-produced plasmas (DPP).



# METROLOGY

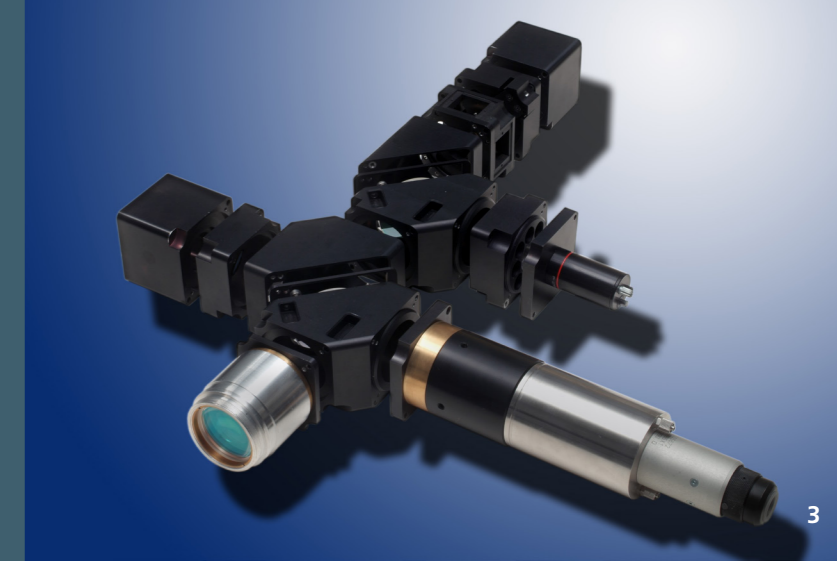
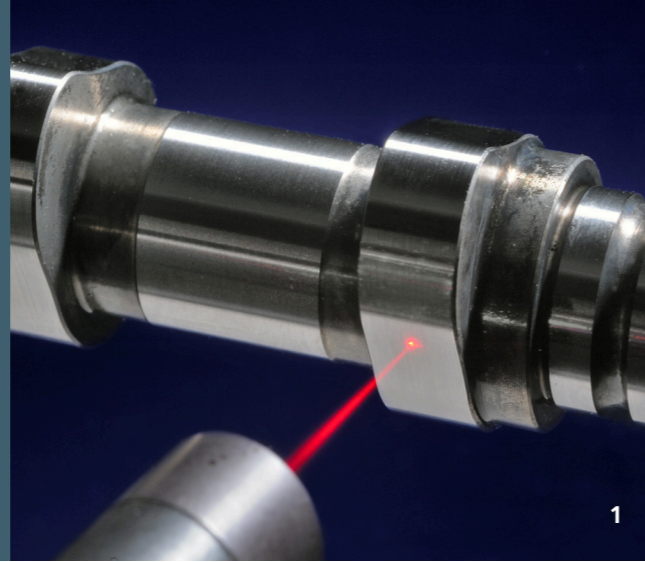

The member institutes of the Fraunhofer Group for Light & Surfaces design and implement optical measurement systems for a range of applications, including component and speed measurements, over a scale of measurement that ranges from nanometers to kilometers. To allow them to determine an object's position and geometry, the group develops 3D measurement systems that draw on special laser scanners and tailor-made lighting and camera systems. Process and material analysis is conducted primarily with spectroscopic measurement techniques and systems. This involves using laser-produced plasmas or absorption and emission spectroscopy to detect characteristic spectral lines or regions for the materials and processes under analysis. Personalized software and hardware solutions enable the measurement technology to be tailored to the specific application.

## Applications

- 3D metrology
- Interferometric and holographic metrology
- Spectroscopic metrology
- Image processing and process control

## 3D METROLOGY

Laser metrology makes it possible to determine the geometric variables of technical components and products, such as gaps, profiles and shapes, and to verify components' position and dimensional accuracy, all without any contact. This technology utilizes triangulation techniques, such as laser-light sectioning, as well as interferometric techniques for absolute measurements. These techniques are particularly useful for inline measurement of geometric variables that move relative to the measurement beam, or else whose state makes contact with a measurement instrument impossible. Measurements can thus be undertaken directly on the production line or in conjunction with a machining process. In addition to developing new measurement techniques, the member institutes also develop a range of solutions, from special lighting arrangements to complete, customer-specific measurement systems, for instance for use in criminology.

## INTERFEROMETRIC AND HOLOGRAPHIC METROLOGY

Interferometric and holographic measurement technology permits ultra-precise measurement of geometrical forms with submicrometer accuracy. An absolute measuring interferometric sensor system developed at Fraunhofer ILT measures distances to technical components in a measuring range of 8 mm (with typical working distances of 50 to 200 mm) with

1 Testing a camshaft for shape

and position tolerances.

2 A high-speed 3D sensor.

3 CPC inline process measurement technology.

an accuracy of < 200 nm. The system can also determine roughness characteristics in the submicrometer range. In the field of holographic measurement technology, Fraunhofer IOF uses special computer-generated holograms (CGH) to enable high-precision measurement of optical freeforms. Fraunhofer IPM is working on a digital holographic 3D measurement technology that enables rapid (subsecond range) and simultaneously high-precision ( $\mu\text{m}$  range) measurement of 3D geometries.

## SPECTROSCOPIC METROLOGY

Laser spectroscopic methods make it possible to conduct chemical analyses of materials in all aggregate states. Reflection, transmission and absorption measurements can be used along with fluorescence and Raman spectroscopy to determine characteristic features and compositions of molecules and materials. Laser-induced breakdown spectrometry (LIBS) is one of the key techniques developed at Fraunhofer ILT to enable multielement analysis supplemented by molecular or crystal structure information. When laser ablation techniques are integrated into the process, coated and contaminated materials can also be tested to determine their core composition. In the field of gas and particle measurement technology, Fraunhofer IPM uses IR spectroscopy in a similar way, for instance to measure hydrocarbons in passenger

vehicle emissions. The modular MOCCA+® monitoring system developed by Fraunhofer IST to monitor and fully automate coating systems for producing (precision) optical systems uses in situ measurements of transmission and reflection spectra ranging from UV to NIR. Fraunhofer IWS employs laser-diode spectroscopy to determine the water vapor transmission rate of flexible ultra-barrier systems up to 10 - 6 grams per square meter per day. It also makes use of hyperspectral imaging (HSI) to provide spectroscopic imaging in the near infrared (NIR), visible (VIS) and ultraviolet (UV) range. This facilitates temporally and spatially resolved measurement of all spectral features, and thus a complete and comprehensive analysis of the product or process under investigation.

## IMAGE PROCESSING AND PROCESS CONTROL

Thanks to the high-speed cameras available today, image processing offers numerous options for rapid analysis in component testing and process measurement. For laser processing applications, these high-speed imaging systems can be integrated into the beam path of laser processing systems and, using hardware-based image processing and cognitive methods, provide robust, unambiguous process monitoring and control results, making it possible to boost productivity across a range of manufacturing tasks. Fraunhofer ILT and Fraunhofer IWS develop highly integrated process measurement systems for rapid analysis of melt dynamics during welding, coating, cutting and ablation.

# MEDICINE AND LIFE SCIENCE

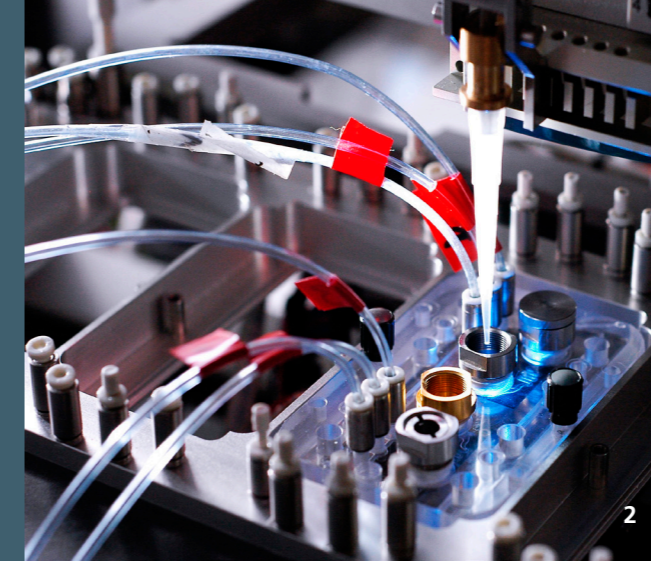
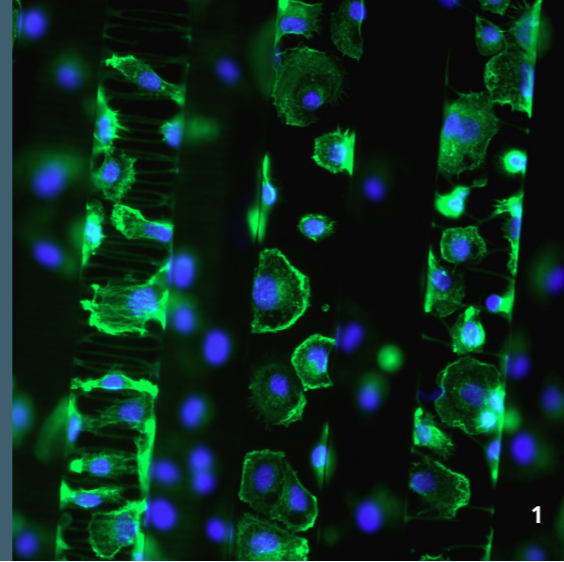

Photonic processes can be found in a variety of medical and biotechnological applications. Starting from direct medical treatments that use laser radiation and light for surgical procedures and biostimulation, optical processes are now found primarily in diagnostics. Here, the member institutes of the Fraunhofer Group for Light & Surfaces develop new techniques and medical treatment systems that are often implemented in collaboration with the member institutes of the Fraunhofer Group for Life Sciences. The institutes also develop diagnostic and analytical techniques such as plasma, Raman and fluorescence spectroscopy, which enable the structural data of proteins, binding states and optical markers to be detected and used in medical and biotechnological processes.

## Applications

- Laser medicine
- Laser diagnostics
- Biotechnology and bioanalytics
- Biofabrication

## LASER MEDICINE

Laser medicine is perhaps the best-known medical photonic application, since topics such as LASIK, photodynamic therapy, and wrinkle and tattoo removal have become mainstream. Ultrafast lasers, in particular, are ideal tools for cutting into tissue with minimal thermal damage, for instance to perform bone resections or remove tumors. Fraunhofer ILT develops various technological approaches and systems for surgery and minimally invasive therapy. Laser and plasma processes are employed to produce medical devices, such as patient-specific implants and micro-perforated balloon catheters that permit precision dosing of medications. Laser technology is also being used to produce biofunctional coatings that boost products' biocompatibility. Here, treating medical devices with low-energy electrons has proven an effective tool in reducing pathogens, sterilizing packaging, implants and medical equipment, and inactivating liquid pathogen suspensions.

## LASER DIAGNOSTICS

By drawing on laser and photodiagnostic methods, researchers can use such techniques as fluorescence diagnostics and Raman spectroscopy to identify specific molecules and their composition, as well as to detect specific cell types using suitable markers. Raman spectroscopy makes it possible to capture and characterize, for instance, information-rich spectra of individual cells, then use them to distinguish differentiated stem cells,

resolve cell cycles, monitor activation processes and determine stress states. Raman spectrometers can also be used to analyze extracellular media. In addition to direct laser sensor systems for biological and medical applications, lab-on-a-chip systems are also used for in situ analysis, enabling rapid diagnostics and a more targeted selection of drugs. One of the member institutes' key areas of expertise in this field is high-sensitivity real-time readout based on the evanescent-field technique.

## BIOTECHNOLOGY AND BIOANALYTICS

By combining microfluidic systems with optical technologies, researchers at the member institutes of the Fraunhofer Group for Light & Surfaces have been able to create innovative miniaturized analysis and diagnostic systems for use in medical diagnostics, biotechnology and analytics. As miniaturized probes and optics are developed and adapted to the requirements of specific applications, we are seeing the emergence of innovative new measurement techniques that can be used to acquire spectroscopic information in chemical and biotechnological processes – even inline – thus enabling real-time process monitoring. Special lab-on-a-chip systems developed at Fraunhofer IWS address both medical applications (organ-on-a-chip) and issues of biosystem technology.

## BIOFABRICATION

Biofabrication is a fast-growing field that calls for researchers to explore new concepts and tools for biomedical applications such as diagnostic systems and models for pharmaceutical and cosmetic tissue and organ testing. The activities of the member institutes of the Fraunhofer Group for Light & Surfaces are thus focused on techniques such as 3D printing of biocompatible materials for producing support structures for artificial blood vessels and organs, as well as the direct printing of living cells. Fraunhofer ILT pursues new approaches for rapid printing of biocompatible polymers, the development of new resin formulations with no toxic components, and processing techniques for flexible printing of functional cell constructs. Its research into laser-assisted processes for selecting and printing cells facilitates not only the development of specific cell microenvironments for cell biology research, but also improved tissue models and even the printing of artificial organs and organ components. The member institutes also develop various methods to functionalize structures and scaffolds.

- 1 Automated pipette filling of a multi-organ chip.
- 2 Cells on TPP generated protein structures.
- 3 A plasma-coated sac.



# OPTICAL SYSTEMS AND OPTICS MANUFACTURING

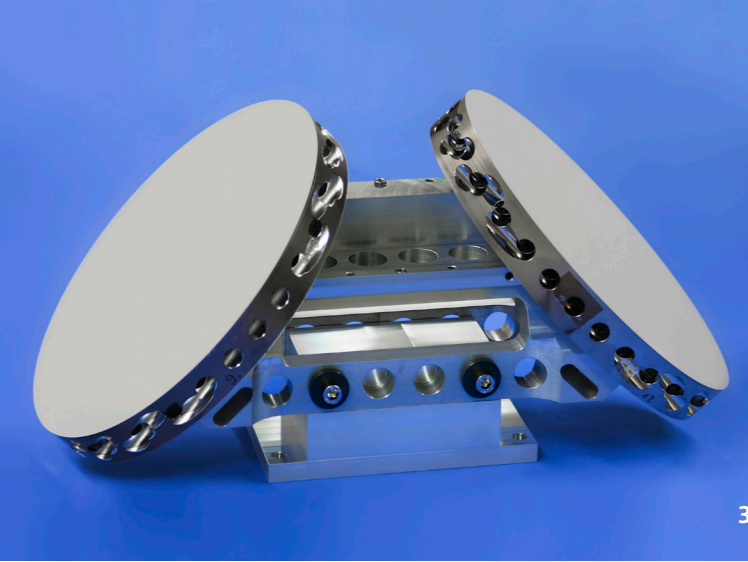
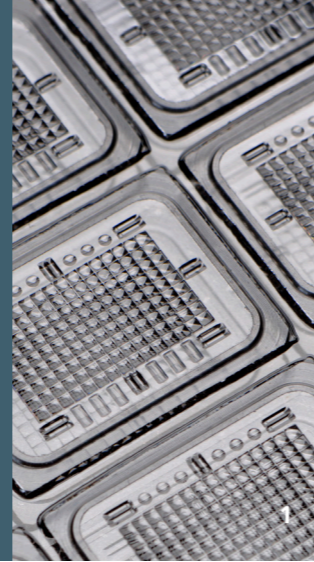

The member institutes of the Fraunhofer Group for Light & Surfaces develop optical systems for a variety of applications in laser and measurement technology, lighting engineering and materials analysis. They develop and manufacture customer-specific optical systems from prototype to finished product. Their optical developments encompass the overall system technology as well as individual manufacturing steps, such as the production of lenses and mirrors for space applications and beam-shaping and deflecting mirrors for EUV lithography.

## Applications

- Optics design
- Optics manufacturing
- Optical systems
- Optics assembly

## OPTICS DESIGN

Member institutes' activities in this domain cover the entire chain of optical design, from active, beam-emitting systems and components for beam transmission and beam shaping to system integration. Fraunhofer IOF and Fraunhofer ILT, for instance, develop diffractive and refractive optical elements, integrated optical components and free-form optics and systems that combine micro-optic and conventional optical components. This includes both the optomechanical and the

optoelectronic system design. Fraunhofer IOF additionally focuses its efforts on mechanical and optics design for large-format optics and highly integrated systems, including optics with low mass and high stability for space applications. Fraunhofer IST and Fraunhofer IPM develop and design optical systems for applications in measurement technology and spectroscopy.

## OPTICS MANUFACTURING

The member institutes of the Fraunhofer Group for Light & Surfaces have a variety of forming and coating techniques at their disposal for the manufacture of optics and optical components. Fraunhofer IOF uses ultra-precision machining to produce metal mirrors, gratings, plastic-based lenses and lens arrays. These are then polished using magnetorheological finishing (MRF) for complex surfaces (aspheres, optical free-form surfaces and arrays) to ensure an ultra-precision finish. Furthermore, lithographic techniques permit the simultaneous manufacture of large numbers of elements with extremely high lateral accuracy, which is vital for micro-optic integration on the wafer scale. In the field of optical coating, Fraunhofer IST developed the EOSS® coating platform, a new system for applying sophisticated optical coatings. This makes it possible to produce extremely low-defect coatings and complicated layer designs with multiple layers while maintaining extreme precision and a uniform coating. Fraunhofer FEP develops processes and technologies that employ vacuum techniques to precisely and uniformly apply electrical, optical, acoustic or magnetically active layers and layer systems on large surfaces.

## OPTICAL SYSTEMS

The member institutes manufacture customer-specific optical systems for use in, for example, measurement technology, laser processing and aerospace. Fraunhofer IOF develops metal- and glass-based high-precision mirror systems for various space applications and wavelength ranges. In the aerospace sector, Fraunhofer IOF researches the design, manufacture and assembly of modern telescope and spectrometer optics with on- and off-axis aspheres and freeform and structured surfaces. Fraunhofer ILT offers a broad array of services specifically for optical systems for high-power lasers, from assembly to characterization, with a focus on multi-beam systems, fast beam deflection systems, and high-precision drilling, cutting and welding optics for laser material processing. Fraunhofer IST develops and produces specially coated components for optical systems. The spectrum ranges from large-area, highly reflective mirrors measuring up to 60 x 80 cm<sup>2</sup> to micro-structured pixel filters for use in 3D metrology.

## OPTICS ASSEMBLY

Fraunhofer ILT and Fraunhofer IOF possess extensive expertise in developing technologies for the high-precision, hybrid integration of different components in order to construct complex optical, optomechanical and optoelectronic systems. This process covers components of varying dimensions – from small single-core emitters to diode laser bars, laser mirrors, laser crystals and non-linear crystals to larger passive optic arrays consisting of several lenses. Components are aligned either passively or actively, using both mechanical and piezo-based high-precision manipulators, permitting accuracies of better than 1 μm and 1 μrad. The melting of the solder is strictly limited, both spatially and temporally, using appropriate current or radiation-based heating methods.

- 1 Micro-optic elements.
- 2 A robustly designed optical parametric oscillator.
- 3 High-precision mirror systems for space applications.



# EUV TECHNOLOGY

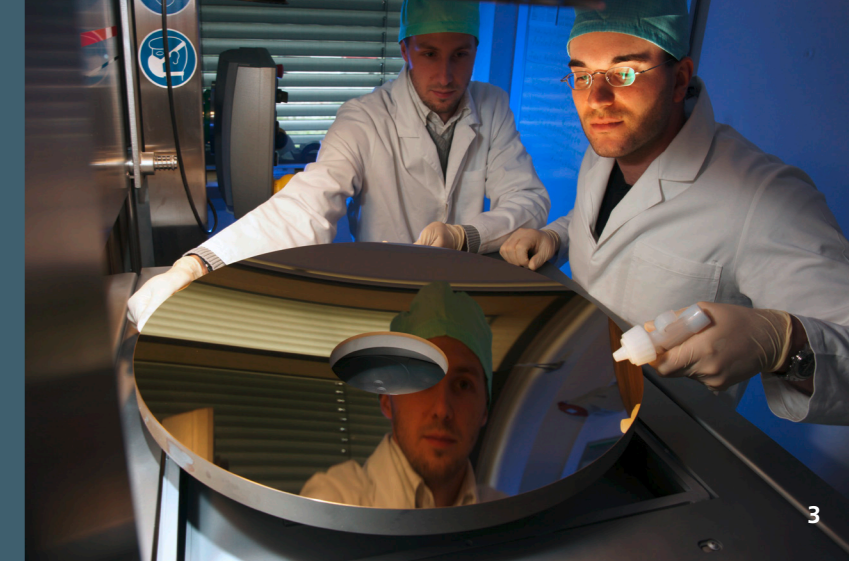
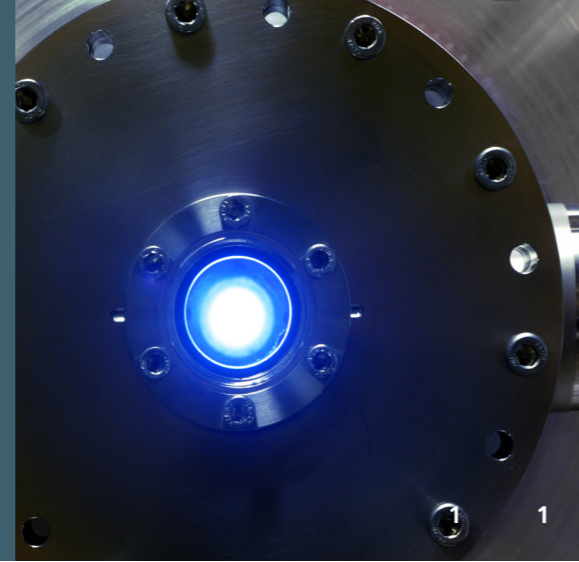

The Fraunhofer Group for Light & Surfaces concentrates its radiation technology activities on lasers with wavelengths ranging from UV to the IR range of 10  $\mu\text{m}$ , although increasingly with wavelength ranges outside of this classical spectrum. Notable examples are the EUV and X-ray radiation ranges which, due to their short wavelengths of 1–50 nm, exhibit special properties and enable innovative new applications – for instance in lithography and high-resolution analytics for medicine. For this, the member institutes develop beam sources from hot plasmas generated by lasers and discharges, as well as through multiple frequency conversion in gases and special resonators.

## Applications

- EUV and X-ray sources
- EUV optics
- EUV metrology and processes

## EUV AND X-RAY SOURCES

Using dense, hot plasmas to generate extreme ultraviolet and soft X-ray radiation in the spectral range between 1 nm and 50 nm enables researchers to design compact and powerful radiation sources. In cases where an application calls for a particularly high-luminosity source, researchers prefer to use laser-induced plasmas over discharge-induced ones. Discharge-induced plasmas, on the other hand, stand out for their high efficiency in converting electrical energy into EUV light, and for their simple construction, making them a cost-effective alternative to laser-induced plasmas. Fraunhofer ILT researches and works with both types of plasmas. Besides developing plasmas, Fraunhofer ILT also develops X-ray and EUV radiation sources that are used today in lithography and metrology applications. Here, the beam sources are used primarily for diagnosing and characterizing optical systems for testing the service life of multilayer mirrors or for inspecting components for defects.

## EUV OPTICS

There are currently no transparent materials available for guiding and shaping EUV and X-ray radiation, and what is more, all materials exhibit high absorption at these wavelengths. Therefore, special multilayer mirrors must be used to guide and shape EUV and X-ray radiation – mirrors that must meet extremely stringent requirements in the coating of monolayers. Fraunhofer IOF designs, develops and optimizes highly reflective multilayer mirrors for applications in the EUV and soft X-ray range. This requires a fundamental understanding of layer growth processes, the use of new design approaches to minimize roughness and interdiffusion at the interfacial surfaces, and the refinement of various coating technologies. Currently, EUV mirrors can be manufactured with diameters of up to 660 mm and with a reflection of almost 70 percent.

Fraunhofer IWS uses magnetron and ion beam sputter deposition and pulsed laser deposition techniques to apply nanometer single and multilayers for EUV and X-ray optics. The layer systems meet the highest requirements with regard to layer thickness accuracy, roughness, chemical purity, lateral homogeneity and reproducibility. When plasma-induced radiation sources are integrated into optical systems, measures are required to protect optical elements against debris from the source (fast ions, electrode material) and to guide the beam in the vacuum. Here, the work at Fraunhofer ILT is aimed at adapting debris mitigation systems while taking into account plasma properties, as well as at achieving the optimum design of collector optics.

## EUV METROLOGY AND PROCESSES

Owing to the short wavelength of EUV light, the trend toward semiconductor lithography in the EUV spectral range entails enormous requirements with respect to the quality of surfaces and layers. To meet these requirements, Fraunhofer IOF develops techniques that enable EUV mirror substrates to be characterized over large areas with a high degree of sensitivity before the coating process begins. This includes wavelength-specific characterization of the reflection and scattering properties of EUV layer systems at 13.5 nm. When combined with the existing Fraunhofer ILT modeling techniques and EUV system technology, the result is a closed chain for the characterization of EUV components.

1 Characterization of EUV layers.

2 Collector mirrors for extreme ultraviolet lithography.

3 Inspecting coated astro-mirrors.

# PROCESS AND SYSTEM SIMULATION

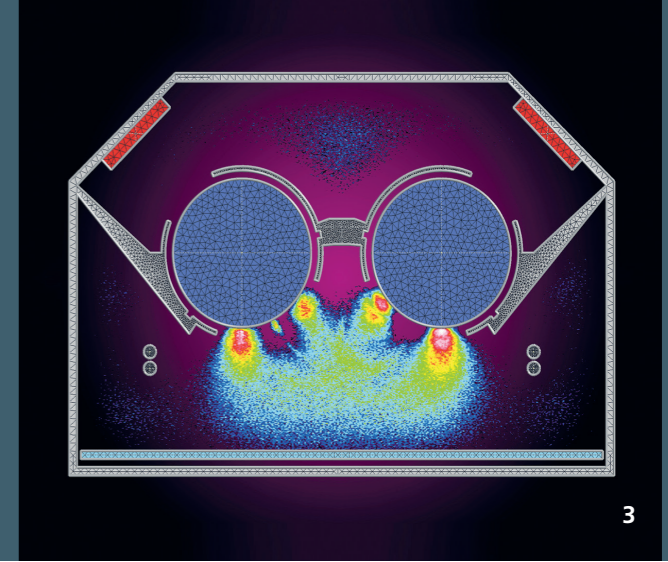
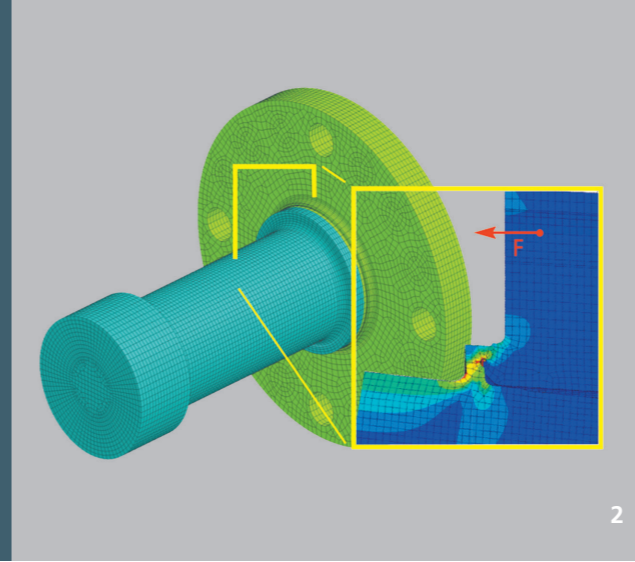
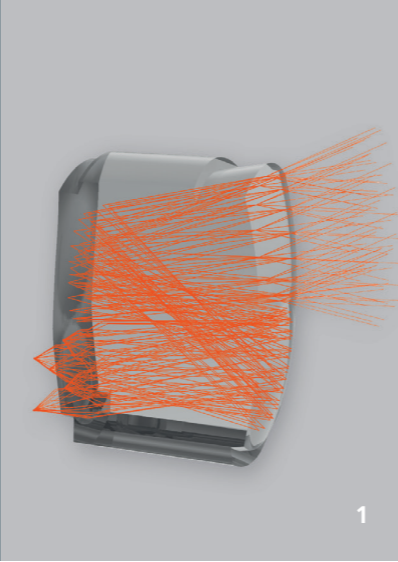

Extensive simulation and in-depth analysis with high temporal and spatial resolution provide an understanding of machining processes and help shorten process chains through the design of new techniques. Member institutes offer a diverse portfolio of simulation programs and bring with them a high level of expertise in optical design, allowing them to design optical systems with maximum integration density and a minimum of optical components. Their tasks include ray tracing, performing complex wave-optical calculations and material simulations, and developing coatings and alloys. To model gas and particle transportation in the low-pressure range, researchers employ various methods including direct simulation Monte Carlo (DSMC) and particle-in-cell Monte Carlo (PIC-MC) technology.

## Applications

- Laser simulation
- Optics simulation
- Process simulation
- Process chain optimization and component design

## LASER SIMULATION

Analysis of optical parameters such as average power, absorption, pulse shape and pulse repetition frequency is key to the development of innovative new laser systems. Fraunhofer IOF and Fraunhofer ILT thoroughly examine laser systems for any modulation instabilities, for instance in beam quality, and develop detailed analyses for new fiber, pump and laser designs to scale the power of high-performance laser systems. The member institutes have a range of calculation tools at their disposal for conducting simulations in the fields of wave optics, geometrical optics, hydro- and structural mechanics, and data analysis. For more extensive analyses, there are also a range of numerical models and tools available to describe and model the complex conditions encountered in a variety of beam source constellations. Finally, the OPT optical lens simulation tools and the design software for free-form optics developed at Fraunhofer ILT aid in optimizing laser and beam source systems.

## OPTICS SIMULATION

Combining mechanical and optical design is one of Fraunhofer IOF's core competencies. This includes the thermal design of optical systems with the aim of rendering them sensitive to the effects of environmental temperature or to thermal lenses in high-power applications. Optical and mechanical simulations and analyses are performed on components and systems, addressing a range of functions and processes – from macro to micro to nano – including OLED simulation and waveguide

design. Free-form design software tools specially developed at Fraunhofer ILT for lighting and complex beam shaping applications make it possible to calculate the design of free-form optical surfaces and to manufacture virtual prototypes.

## PROCESS SIMULATION

Fraunhofer IST offers material simulations for alloy and layer development, for designing alloy heat and diffusion treatments, and for dissolving carbides during austenitization. Fraunhofer IPM developed its own software for describing new module designs and optimizing system integration of thermoelectric materials. Fraunhofer IWS and Fraunhofer ILT use simulations of laser material processing techniques to examine material-related variables and functional dependencies between control, influencing, disturbance and target variables, allowing them to draw conclusions about attainable process efficiencies. To conduct simulations for dimensionally accurate automotive components made of metal powder or plastic-metal compounds, researchers need greater knowledge of realistic material models. This will allow them to define the parameters for more detailed basic material models and develop special simulations of the thermomechanical processes that occur during solidification.

## PROCESS CHAIN OPTIMIZATION AND COMPONENT DESIGN

Mastering multiple, individually weighted requirements (cost, resources, quality, productivity) to design a process chain calls for the use of virtual tools, such as metamodels. The freedom in design and tailored functionality of real products in additive manufacturing requires component design that accounts for both upstream and downstream links in the process chain. Developing integrated, end-to-end design tools, data chains and data standards paves the way for smart design of process chains and component functions, but these require new design approaches. The laser processing techniques developed at the member institutes of the Fraunhofer Group for Light & Surfaces allow components to be adapted to the process and to the load placed on them, enabling developments to be implemented successfully. A similar process chain applies to the procedures for optical components. Fraunhofer IOF designs mechanical and optical systems that meet the final requirements and designs of the components and systems.

- 1 Optical design of a night vision camera.
- 2 Model of a laser-welded shaft-hub connection with voltage distribution under operating load.
- 3 Process simulation.



## Contact

Prof. Reinhart Poprawe (Chairman)  
Steinbachstraße 15  
52074 Aachen, Germany  
reinhart.poprawe@ilt.fraunhofer.de

Dr. Arnold Gillner (Managing Director)  
Steinbachstraße 15  
52074 Aachen, Germany  
arnold.gillner@ilt.fraunhofer.de

[www.light-and-surfaces.fraunhofer.de/en](http://www.light-and-surfaces.fraunhofer.de/en)

## The Fraunhofer-Gesellschaft

The Fraunhofer-Gesellschaft is the leading organization for applied research in Europe. Its research activities are conducted by 72 institutes and research units at locations throughout Germany. The Fraunhofer-Gesellschaft employs a staff of more than 25,000, who work with an annual research budget totaling 2.3 billion euros. Of this sum, almost 2 billion euros is generated through contract research. Around 70 percent of the Fraunhofer-Gesellschaft's contract research revenue is derived from contracts with industry and from publicly financed research projects. International collaborations with excellent research partners and innovative companies around the world ensure direct access to regions of the greatest importance to present and future scientific progress and economic development.

[www.fraunhofer.de/en](http://www.fraunhofer.de/en)